

# ADEZZ

DESIGN TO GROW

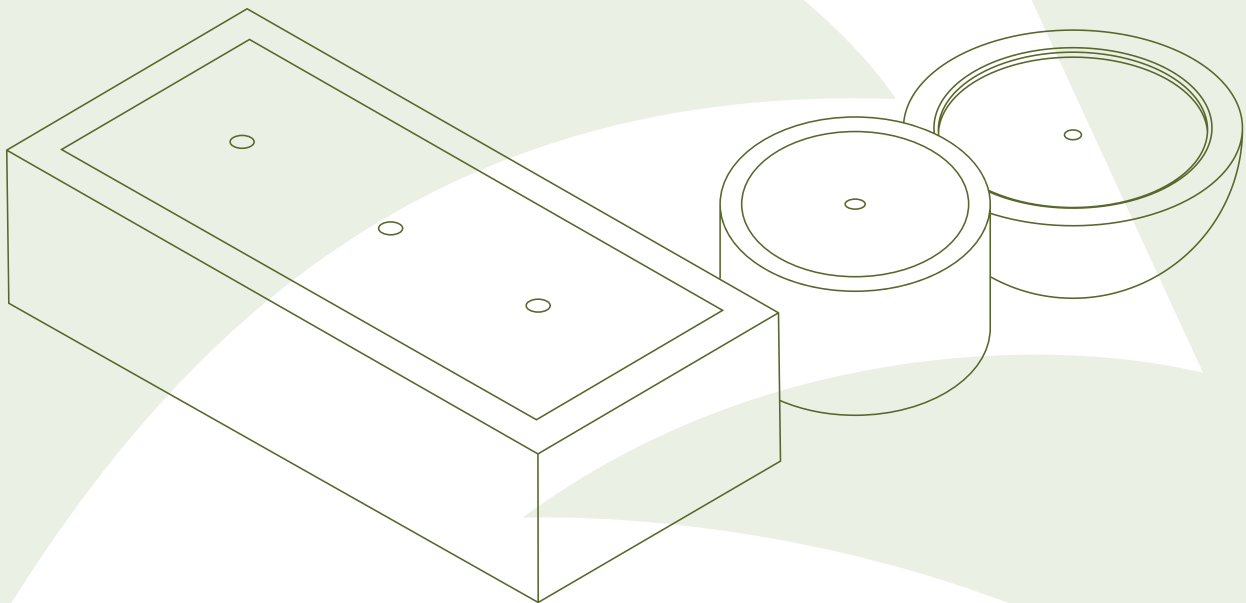

**Manual**

CORTEN STEEL WATER TABLES

# Manual

Corten steel water tables

Thank you for purchasing an ADEZZ corten steel water table. This manual provides the instructions for installing, using, and maintaining our corten steel water table.

**Note!** This manual is not for our water table with bowls.

## REQUIREMENTS

- Power plug with correct IP-class for self-assembly.
- Conduit, e.g., flexible cable protection conduit or hard PVC pipes of approx. Ø60 mm.
- Recommended: wire puller for inserting cables through the conduit.



## Description of parts

The cables in the water table are 10 metres long.

NR.	PARTS
1	Water table top
2	Water table
3	LED fountain
4	Water hose
5	Regulating valve
6	Overflow pipe
7	Rod
8	Pump
9	Six-way distributor

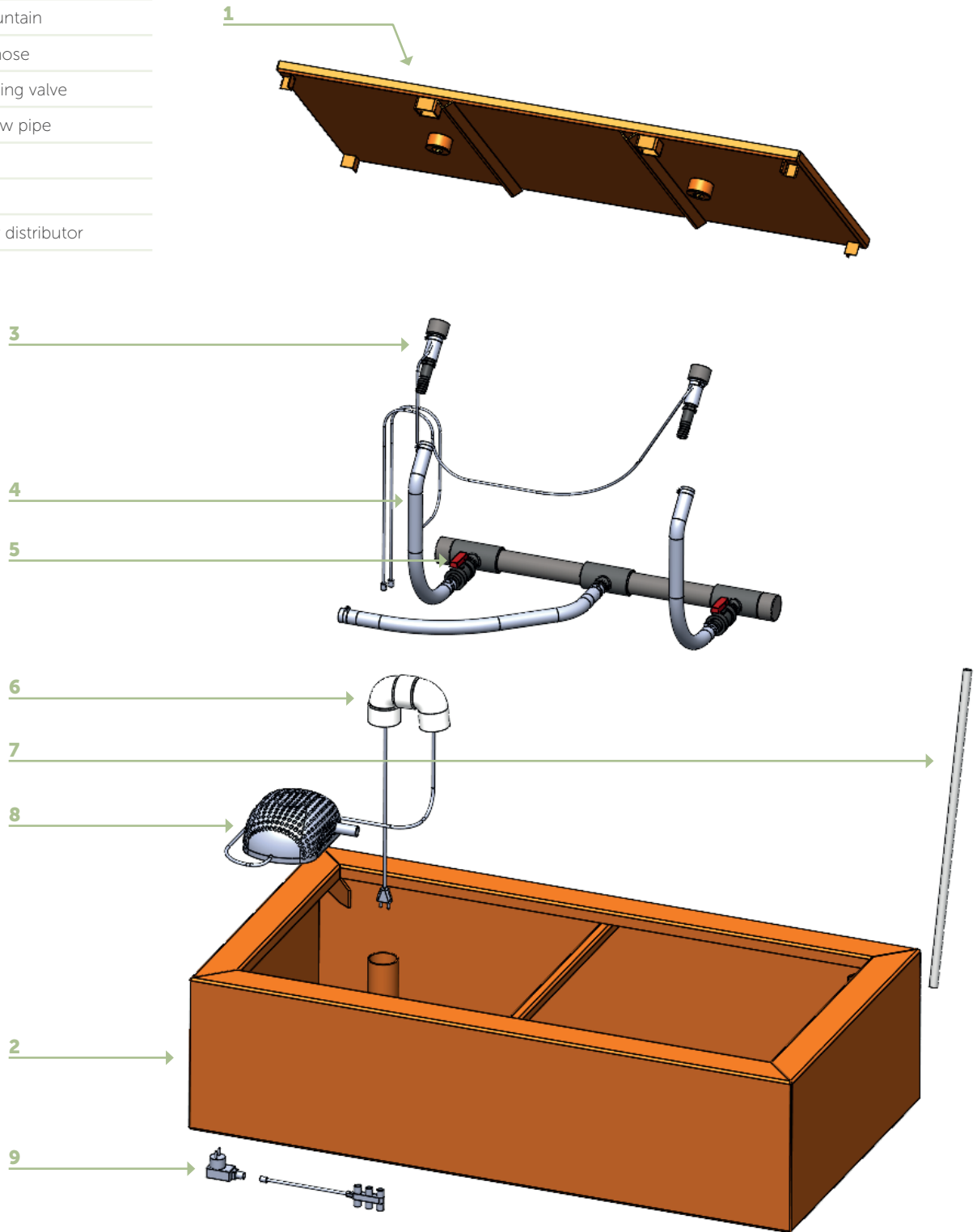

## Description of components

ARTICLE NUMBER	MODEL	DIMENSIONS L x W x H mm	CONTENTS Recommended water content in liters	LED FOUNTAIN Quantity	WATER TAPS Quantity	PUMP Quantity	ROD Quantity	ADAPTERS (for LED)	SIX-WAY DISTRIBUTOR Quantity	RODS Quantity
CB1	Square water table	6000 x 1000 x 400	1500	6	6	VP4	3	2	2	3
CB2	Square water table	5000 x 1000 x 400	1250	5	5	VP4	2	2	2	2
CB3	Square water table	4000 x 1000 x 400	1000	4	4	VP3	2	1	1	2
CB4	Square water table	3000 x 1000 x 400	750	3	3	VP3	2	1	1	2
CB4.1	Square water table	3000 x 800 x 400	600	3	3	VP3	2	1	1	2
CB4.2	Square water table	3000 x 600 x 400	450	3	3	VP3	2	1	1	2
CB5.1	Square water table	2000 x 800 x 400	400	2	2	VP3	1	1	1	1
CB5.2	Square water table	2000 x 600 x 400	300	2	2	VP3	1	1	1	1
CB6.1	Square water table	1500 x 800 x 400	300	2	2	VP3	1	1	1	1
CB6.2	Square water table	1500 x 600 x 400	225	2	2	VP3	1	1	1	1
CB7.1	Square water table	1200 x 800 x 400	240	2	2	VP3	1	1	1	1
CB7.2	Square water table	1200 x 600 x 400	180	2	2	VP3	1	1	1	1
CB11	Square water table	1200 x 1200 x 400	360	1	1	VP1	-	1	-	-
CB12	Square water table	1000 x 1000 x 400	250	1	1	VP1	-	1	-	-
CB13	Square water table	800 x 800 x 400	160	1	1	VP1	-	1	-	-
CB14	Square water table	600 x 600 x 400	90	1	1	VP1	-	1	-	-
CBR1	Round water table	1450 x 750	825	1	1	VP1	-	1	-	-
CBR2	Round water table	1200 x 750	565	1	1	VP1	-	1	-	-
CBR3	Round water table	1000 x 750	390	1	1	VP1	-	1	-	-
CBR4	Round water table	1450 x 400	395	1	1	VP1	-	1	-	-
CBR5	Round water table	1200 x 400	270	1	1	VP1	-	1	-	-
CBR6	Round water table	1000 x 400	185	1	1	VP1	-	1	-	-
CBR7	Round water table	800 x 400	120	1	1	VP1	-	1	-	-
CBB1	BAYOU	1200 x 531	190	1	1	VP1	-	1	-	-
CBB2	BAYOU	1000 x 437	140	1	1	VP1	-	1	-	-



## CHAPTER 1: SAFETY

1.1 Safety instructions	6
-------------------------	---

## CHAPTER 2: RECEIPT

2.1 Unpacking and inspection	6
------------------------------	---

## CHAPTER 3: PLACING & INSTALLING

3.1 Before installation	6
3.2 Installation step by step	7
3.3 After installation	10
3.4 Adjusting the fountains	10

## CHAPTER 4: INSTRUCTIONS FOR USE

4.1 Drawing of the water table	11
4.2 Opening and closing the water table	11
4.3 Filling and emptying	13

## CHAPTER 5: MAINTENANCE

5.1 Water quality	14
5.2 Pump maintenance	15
5.3 Maintenance of corten steel	15
5.4 Maintenance of overflow pipe	15
5.5 Removing lime deposits	15
5.6 Replacing the light	16
5.7 Replacing the pump	19
5.8 Fountain maintenance	19
5.9 Use in frost	22



## Chapter 1: Safety

Read these safety instructions carefully before using the water table.

### 1.1 SAFETY INSTRUCTIONS

- Always move the water table with at least 2 people. Improper lifting or moving with too few people can cause physical injury.
- The water table contains electrical components. Not strictly following the instructions can cause serious, potentially life-threatening situations.
- Be careful with all maintenance and cleaning activities. First, turn off the electricity to prevent short circuits in case of damage to the electrical installation.
- Be cautious with body parts in the water table when the pump is on. Always unplug the water table before opening it.

## Chapter 2: Receipt

### 2.1 UNPACKING AND INSPECTION

- Always move the water table with at least 2 people. Improper lifting or moving with too few people can cause physical injury.
- Unpack the product immediately upon receipt. If not done, unwanted stains and/or an irregular rust process may occur on the product due to moisture trapped between the packaging and the material.
- Corten steel products are delivered not rusted. The rusting process of corten steel takes about 4 to 5 months, depending on weather conditions. For more information about the rusting process of corten steel, visit: <https://www.adezz.com/en-gb/materials/corten-steel>

## Chapter 3: Placing & Installing

- Our water tables are partially assembled upon delivery. The warranty will be void if you grind or drill in a way not prescribed in this manual.
- During the rusting process of corten steel, rust water may come from the product for up to 2 years after receipt. This can cause stains on clothing and the surface where the product is placed. Keep this in mind during placement.
- Ensure proper water drainage from the water table. Do this by not placing the water table too close to walls, fences, etc., and to ensure the overflow pipe is free.
- The ground on which the water table stands must be permeable. If this is not the case (e.g., clay soil), first apply a layer of permeable sand or gravel.

### 3.1 BEFORE INSTALLATION

Follow the steps below before placing the water table.

**Note!** Do not lay the cables unprotected in the ground. Use a conduit to prevent damaged cables from, for example, pests. The conduit is not included. Buy a conduit long enough for the cables (approx. 60 cm). See Chapter 2 'Description of parts' for the diameter and length of the cables.

1. Dig a trench from the socket to the place where the overflow pipe of the water table will eventually come. The trench must be at least 60 cm deep.
2. Lay the conduit in the trench.
3. Fill the trench with soil.
4. Ensure a flat, firm (compacted) surface that is permeable to water.



**Note!** If this is not done carefully, tensions may arise in the product. This can result in damage to the product.

**Note!** Ensure that excess water can drain well through the bottom.

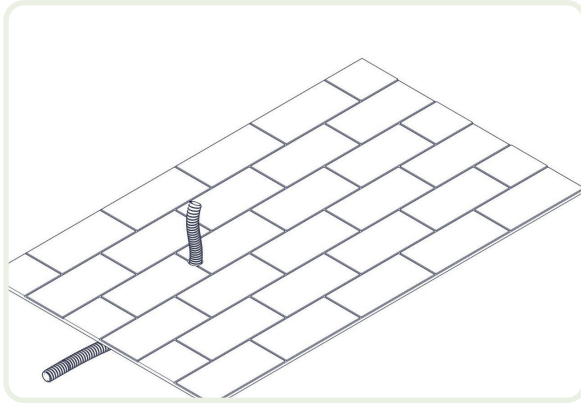

### 3.2 INSTALLATION STEP BY STEP

Follow the steps below when installing the water table.

1. Place the water table with at least two people at the desired location, over the previously installed conduit.

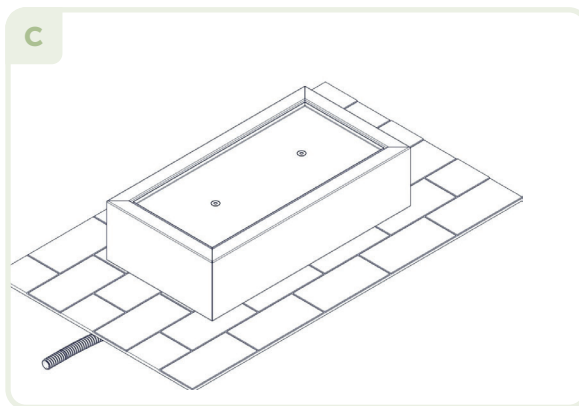
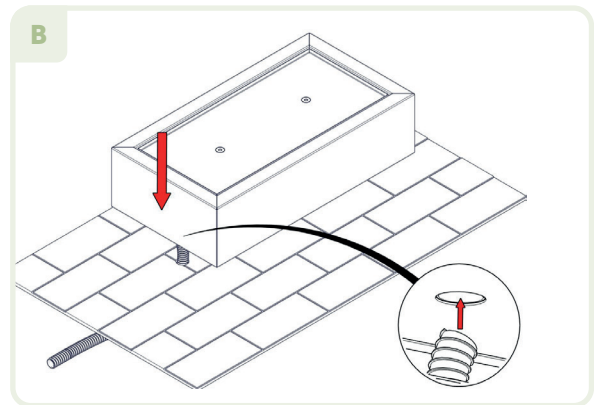
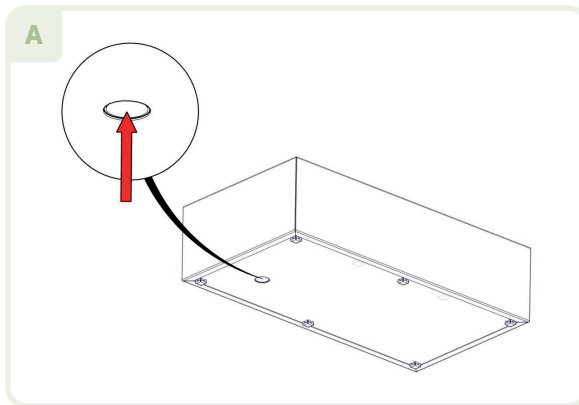

- Carefully open the water table. Do this by lifting the water table cover with at least two people.  
**Note!** Open the water table carefully. If not done carefully, you may pull cables loose or break them.

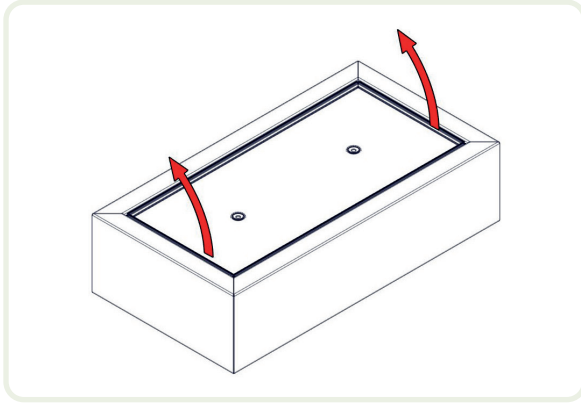

- Take the supplied rods out of the water table and place them in the designated hole.  
**Note!** No rods are supplied with water tables with 1 LED.
- Secure the top of the rod in the lid.

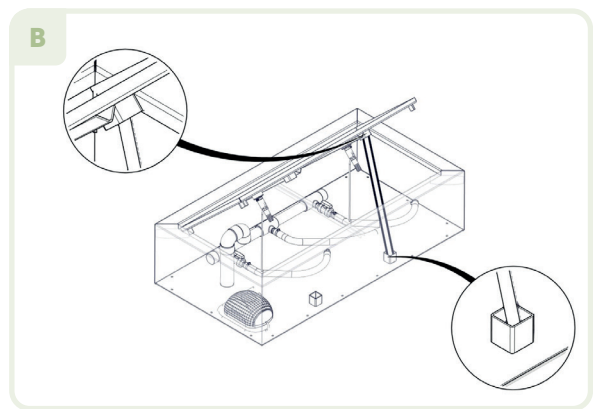
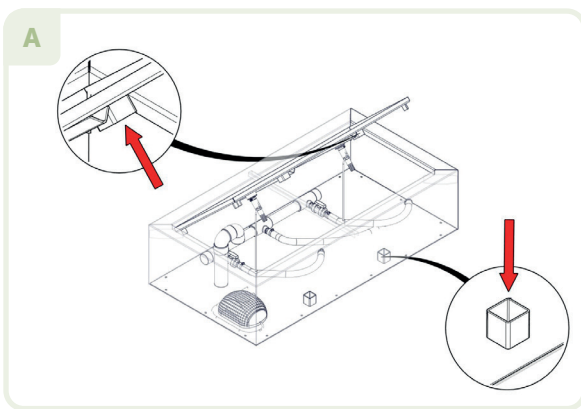

- Carefully release the cover to see if it stays in place.
- Connect the hose of the water installation to the pump. Do this by sliding the hoses over each other and securing them with the hose clamps attached to the hoses.

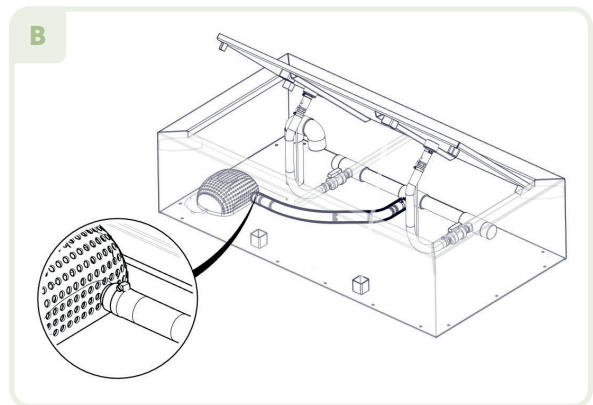
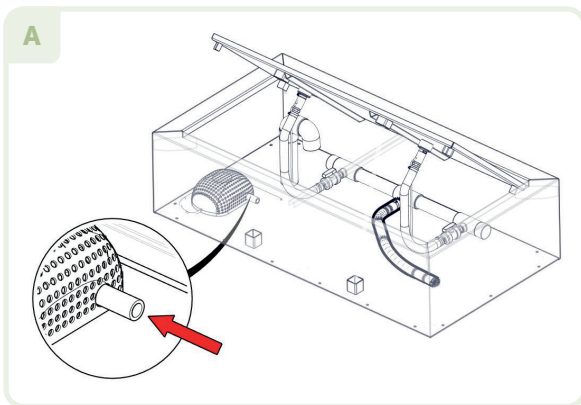



7. Connect the ends of the LED fountains to the water hoses in the water table. Do this by sliding the hoses over each other and securing them with the hose clamps attached to the hoses.

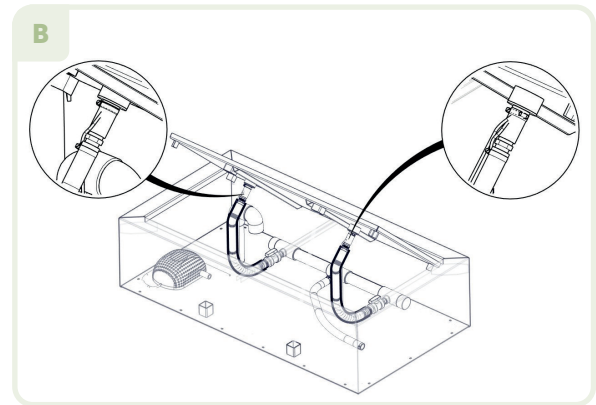
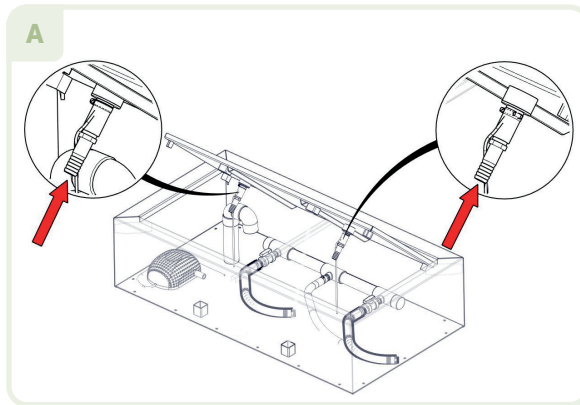

**Note!** With the water table with 1 LED, the pump is already pre-assembled at the end of the LED. This does not need to be done anymore.

**Note!** With a water table with more than 2 LED fountains, the hoses are connected using a Y-piece instead of a T-piece.

8. Pass the cables from the water table through the grommet to the socket. Use a pull wire if necessary.

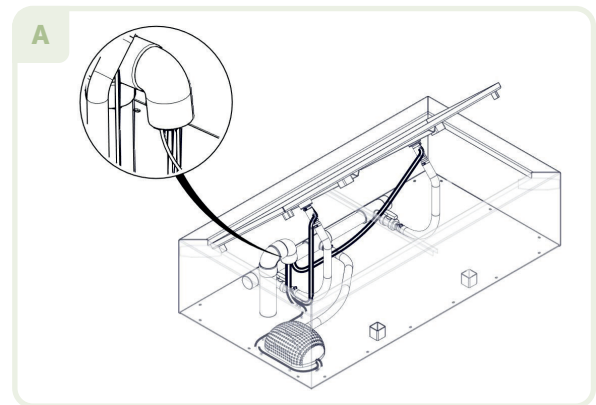
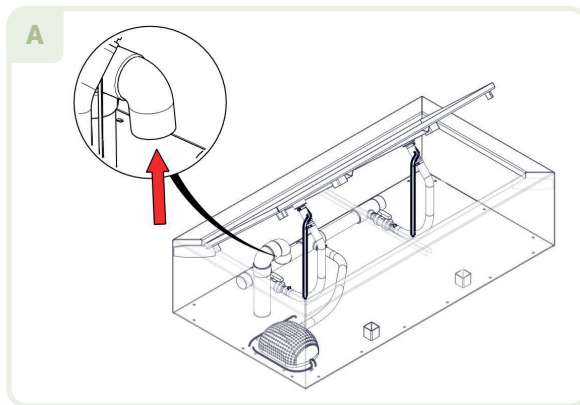

9. Fill the water table with water until it flows out through the overflow pipe. See paragraph 5.3. 'Filling and emptying' for filling instructions.

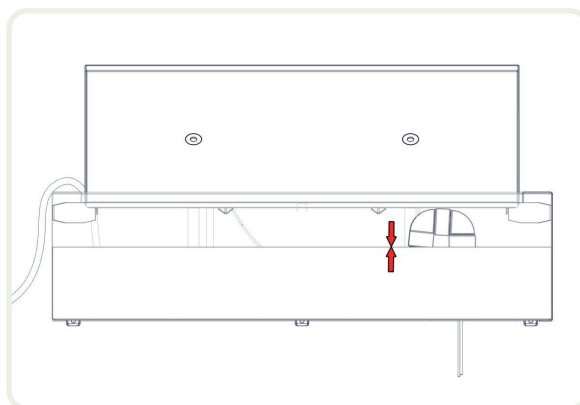

**10.** Carefully lift the cover of the water table with at least 2 people.

**11.** Remove the rods from under the water table lid.

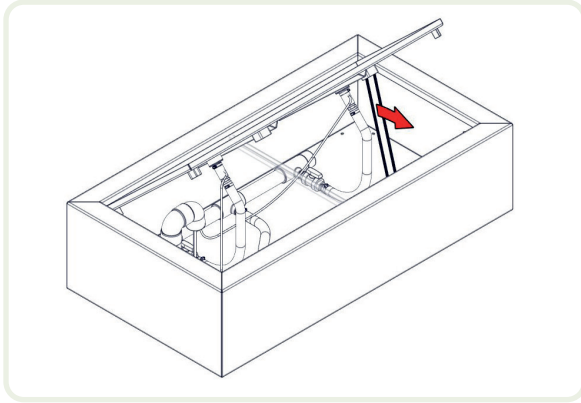

**12.** Carefully lower the cover until it is stable.

**Note!** Ensure that no cables are pinched when the water table cover closes.

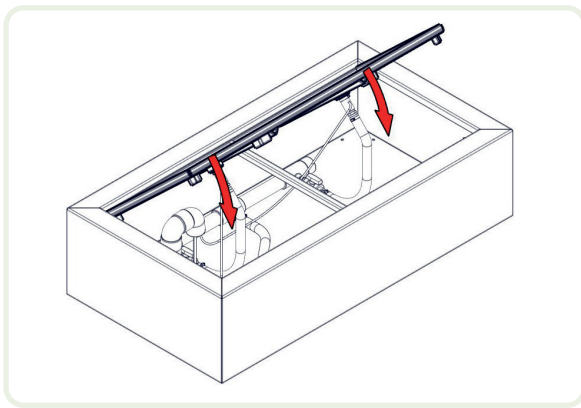

The rods for opening the water table are made of bare steel. Store them in a dry location after use to prevent rusting.

### 3.3 AFTER INSTALLATION

- **Note!** It is important to regularly check the pH value of the water from the first filling. Water with an incorrect pH value can damage the corten steel. See also paragraph 6.1 'Water quality'.
- The rusting process of corten steel takes about 4-5 months, depending on weather conditions. Regularly check the pH value of the water during this time. Rust water can affect the pH value. See also paragraph 6.1 'Water quality'.
- Never place paving tightly against the water table, always keep some distance.

### 3.4 ADJUSTING THE FOUNTAINS

- The adjustment valves in the water table regulate the water supply to the fountains. This allows the fountain to be adjusted as well.
- After placing and filling the water table, always turn on the water table first. This way, you can see if the fountains need to be set harder or softer.
- The water from the fountains should come out of the fountain in a straight stream about 10 centimeters high. If this is not the case, see paragraph 6.8 'Fountain Maintenance'.

**Note!** Do not open the cover of the water table when there is still water on it. First, unplug the power cord so that the fountains stop. The water will then drain from the cover through the fountains. Once the water has completely drained, the cover can be opened.

1. Unplug the power cords.
2. Open the water table. See paragraph 5.2 'Opening and closing the water table' for the correct way to open the water table.
3. Turn the adjustment valve slightly to the right to make the fountain spray harder and to the left to make it spray softer.
4. Adjust the adjustment valve for each fountain as desired.

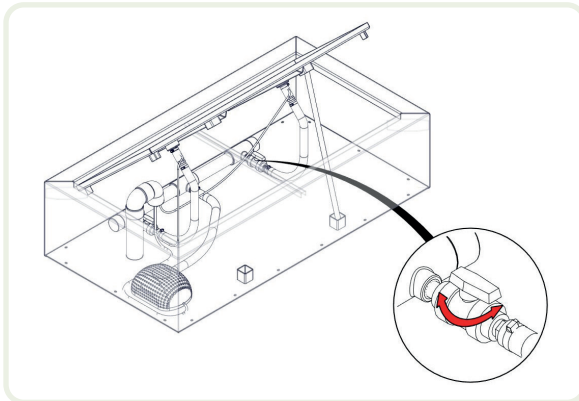

5. Close the water table. See paragraph 5.2 'Opening and closing the water table' for the correct way to close the water table.
6. Turn on the water table and check if the fountains are set correctly. The water from the fountains should come out of the fountains in a straight stream about 10 centimeters high.

Repeat steps 1 to 6 if the fountains do not have the desired setting.

## Chapter 4: Instructions for use

The following explains how to use the water table.

### 4.1 DRAWING OF THE WATER TABLE

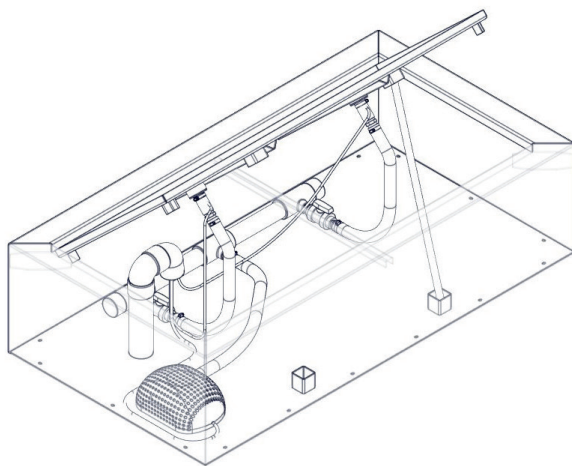

### 4.2 OPENING AND CLOSING THE WATER TABLE

**Note!** Do not open the cover of the water table when there is still water on it. First, unplug the power cord. The water will then drain from the cover through the fountains. Once the water has completely drained, the cover can be opened.

### 4.2.1 Opening the water table

Follow these steps to open the water table:

1. Unplug the power cords.
2. Let the water table cover drain.  
**Note!** Only open the cover when it is completely empty.
3. Carefully open the water table. Do this by lifting the water table cover with at least two people.  
**Note!** Open the water table carefully. If not done carefully, you may pull cables loose or break them.

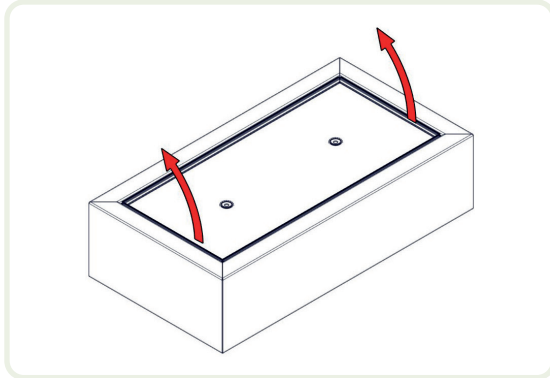

4. Take the supplied rods and place them in the designated hole.  
**Note!** No rods are supplied with water tables with 1 LED.
5. Secure the top of the rod in the lid.

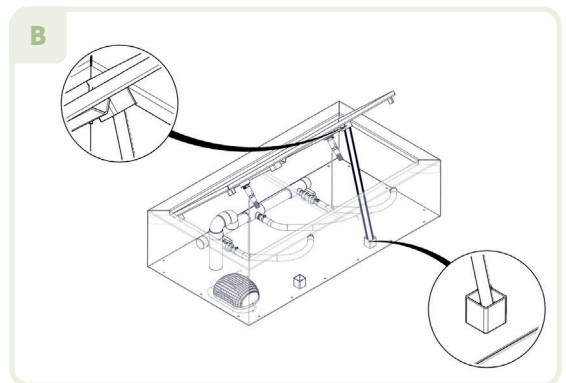
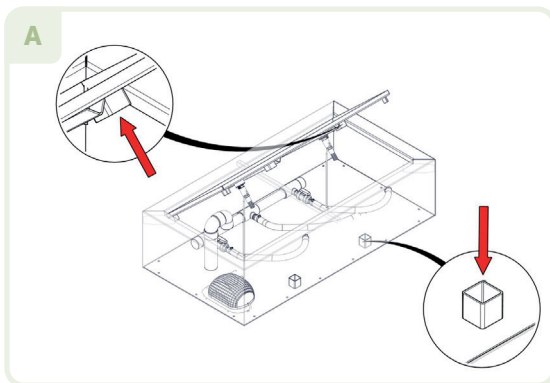

6. Carefully release the cover to see if it stays in place.

### 4.2.2 Closing the water table

Follow these steps to close the water table:

1. Carefully lift the water table cover with at least 2 people.
2. Remove the rods from under the water table lid.

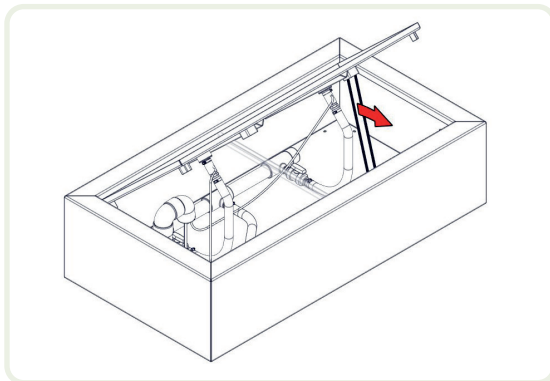

- Carefully lower the cover until it is stable.

**Note!** Ensure that no cables are pinched when the water table cover closes.

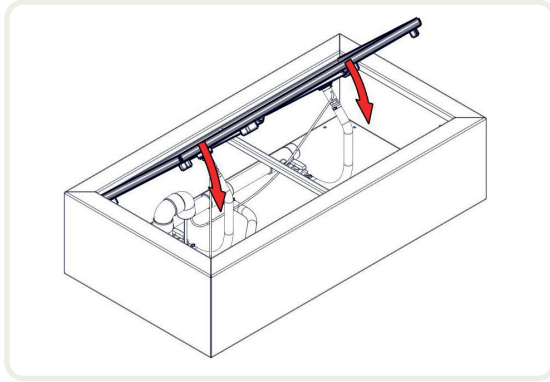

- Plug the power cords back into the socket so that the water table is turned on.

## 4.3 FILLING AND EMPTYING

### 4.3.1 Filling the water table

Follow these steps to properly fill the water table:

- Open the water table. See paragraph 5.2 'Opening and closing the water table' for the correct way to open the water table.
- Hang the garden hose in the water table.

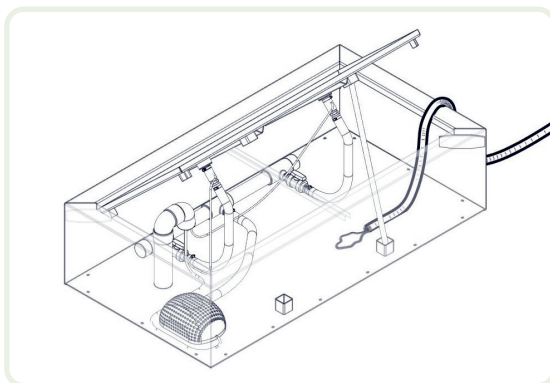

- Fill the water table up to the lower edge of the overflow pipe bend.

**Note!** It is not a problem if the water table is slightly overfilled. The excess water will flow away through the overflow pipe.

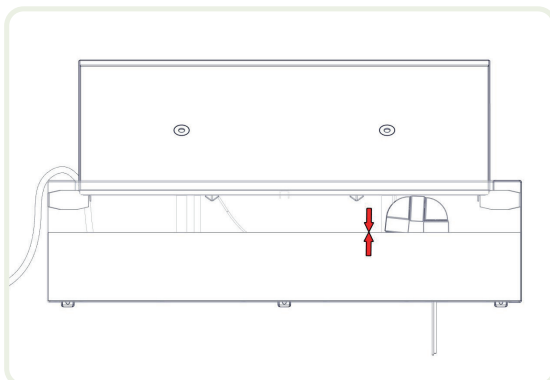

4. Close the water table. See paragraph 5.2 'Opening and closing the water table' for the correct way to close the water table.

**Note!** Regularly check the water level. The water should always reach the overflow pipe. Refill the water table if this is not the case.

#### 4.3.2 Emptying the water table

**Note!** In case of frost, the water table does not need to be emptied, but measures must be taken to prevent damage, such as the pump freezing. See paragraph 6.9 'Use in frost' for use in frost.

**Note!** For maintenance, the water table does not need to be emptied. See Chapter 6 'Maintenance' for maintenance.

Follow these steps to properly empty the water table:

1. Open the water table. See paragraph 5.2 'Opening and closing the water table' for the correct way to open the water table.
2. Empty the water table by placing the pump hose outside the water table.  
**Note!** The pump must always remain underwater! Turn off the pump as soon as the water level is just above the pump.
3. Scoop the remaining water out of the water table until it is completely empty.

## Chapter 5: Maintenance

**Note!** The corten steel water table requires regular maintenance. Empty the water table completely every 3 months, clean it thoroughly, and refill it with clean water. This prevents damage from, for example, rust water. Additionally, regularly check the pH value. It should be neutral (7).

- See paragraph 5.3.2 'Emptying the water table' for instructions on emptying the water table.
- Refer to the information below for maintenance and cleaning of the water table.

**Note!** Be careful with all maintenance and cleaning activities. First, turn off the electricity to prevent short circuits in case of damage to the electrical installation.

### 5.1 WATER QUALITY

#### 5.1.1 Acidity

- **Note!** The water table is a maintenance-sensitive product. The pH value of the water must always be neutral (7).
- It is important to test the pH value of the water once every 2 weeks after installation and during the first use. If the pH value remains neutral (7), the testing frequency can be reduced. Keep checking regularly!
- Use only pH+ and pH- to neutralize the water (7). Using other products may void the warranty.
- Always follow the (safety) instructions of the pH+ and pH- product. The product must always be added to the water, not to an empty water table.
- If the pH value is not kept neutral (7), it can damage the corten steel.

#### 5.1.2 Lime

- When measuring the pH value, also check for lime deposits. Lime will mainly form on the edges of the water table, for example, due to splashing water.
- Remove lime using ADEZZ BIO descaler. Always follow the (safety) instructions on the label. See paragraph 6.5 'Removing lime deposits' for instructions on lime removal.

#### 5.1.3 6.1.3 Coarse contamination

Blown-in leaves and branches should be removed from the water table lid. They negatively affect the water quality and the quality of the material.

Small stones, rust particles, etc., larger than 5 mm are retained by the filter in the pump. The filter must be cleaned regularly. Otherwise, the pump may start buzzing or break.



#### 5.1.4 Organic contamination

Contamination caused by substances and bacteria adhering to the material, such as green deposits on the water table. It is important to maintain corten steel properly. See paragraph 6.3 'Maintenance of corten steel' for corten steel maintenance.

#### 5.1.5 6.1.4 Chlorine & salt

Do not add chlorine or salt to the corten steel water table, as this can damage the material. These substances cause accelerated corrosion, which affects the protective rust layer of the corten steel.

### 5.2 PUMP MAINTENANCE

Small stones, rust particles, etc., larger than 5 mm are retained by the filter in the pump. The filter must be cleaned regularly. Otherwise, the pump may start buzzing or break.

Follow the pump manual for cleaning the pump. The pump manual is included with the water table. If the manual is missing, contact our customer service

### 5.3 MAINTENANCE OF CORTEN STEEL

- Clean the water table every six months by spraying off coarse dirt with tap water. Use a garden hose or pressure washer for this.
- Products are delivered unrusted. The rusting process of corten steel takes about 4-5 months, depending on weather conditions. Regularly check the pH value of the water during this time.

**Note!** Use rust accelerators or stoppers only on the outside of the water table and not on the lid. After treating the water table with rust accelerators or stoppers, check the pH value of the water. The pH value of the water must always be neutral (7). See paragraph 6.1 'Water quality' for proper maintenance of the water's pH value.

**Note!** Do not add chlorine or salt to the corten steel water table, as this can damage the material. These substances cause accelerated corrosion, which affects the protective rust layer of the corten steel.

### 5.4 MAINTENANCE OF OVERFLOW PIPE

Flush the overflow of the water table every six months. Do this as follows:

1. Unplug the power cords.
2. Open the water table. See paragraph 5.2 'Opening and closing the water table' for the correct way to open the water table.
3. Hold the garden hose against the overflow (Overflow pipe number X in picture Y).
4. Turn on the tap so that water flows through the garden hose.
5. Ensure that water flows through the overflow. Check if there is anything stuck in the overflow.
6. Rinse the overflow pipe clean.
7. Close the water table. See paragraph 5.2 'Opening and closing the water table' for the correct way to close the water table.

### 5.5 REMOVING LIME DEPOSITS

When measuring the pH value, also check for lime deposits. Lime will mainly form on the edges of the water table, for example, due to splashing water. It is necessary to remove the lime deposits.

Follow these steps to remove lime.

**Note!** Always follow the safety instructions on the label of the lime remover.

1. Unplug the power cord.
2. Ensure that the surface of the water table is empty.
3. Spray the lime remover from the bottle onto the areas with lime deposits.
4. Let it sit for a few seconds.
5. Rub the lime remover in circles with a soft sponge.
6. Rinse with clean water.



**Note!** After descaling the water table, test the pH value of the water. Do this as soon as you have turned the water table back on and the surface is filled. The pH value of the water must always be neutral (7). See paragraph 6.1 'Water Quality' for proper maintenance of the pH value of the water.

## 5.6 REPLACING THE LIGHT

**Note!** Zorg dat de LED fontein recht in het blad van de watertafel bevestigd is en dat de waterslang niet scheef zit. Hierdoor kan de fontein scheef spuiten.

Gebruik in geval van vervanging, alleen door ADEZZ geleverde elektronische onderdelen.

1. Unplug the power cords.
2. Open the water table. See paragraph 5.2 'Opening and closing the water table' for the correct way to open the water table.
3. Replace the LED fountain as follows:
  - A. Loosen the hose clamp.

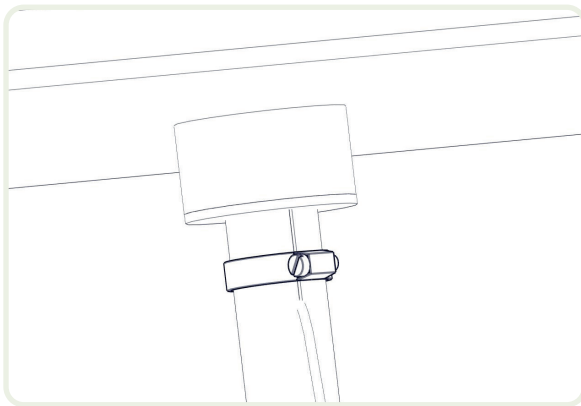

- B. remove the water hose from the LED.

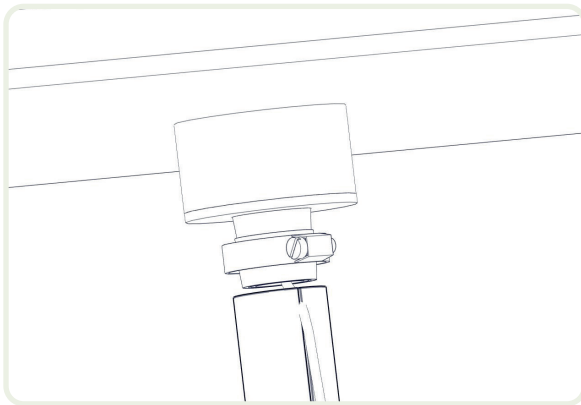



**C.** Remove the LED fountain from the water table surface.

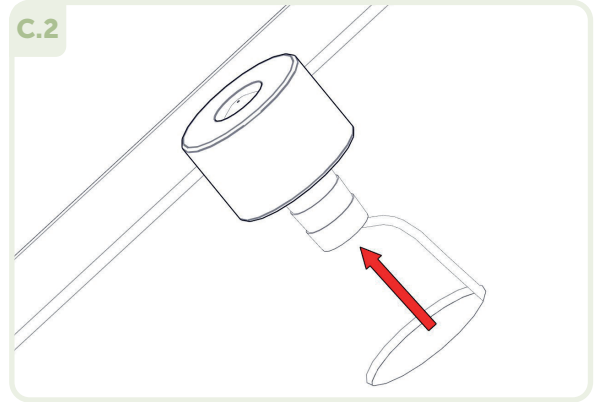
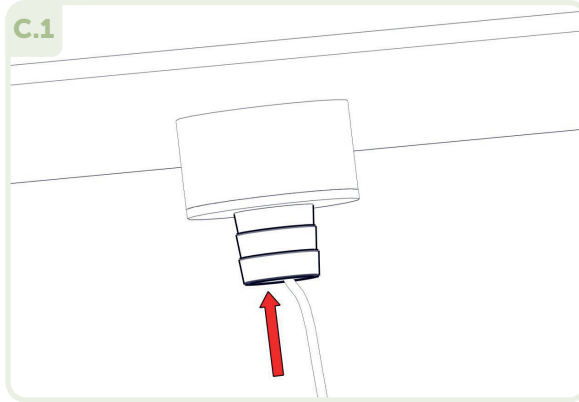

**D.** Unscrew the cap from the LED.

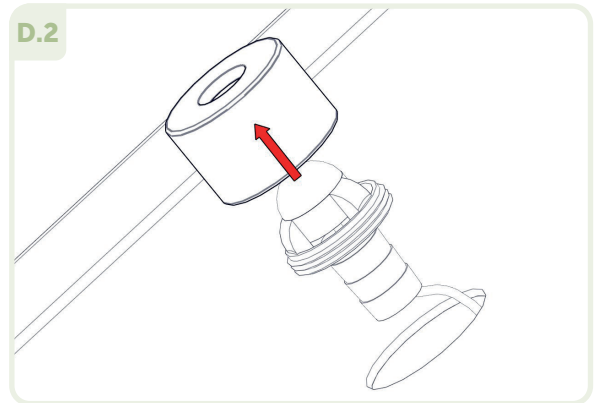
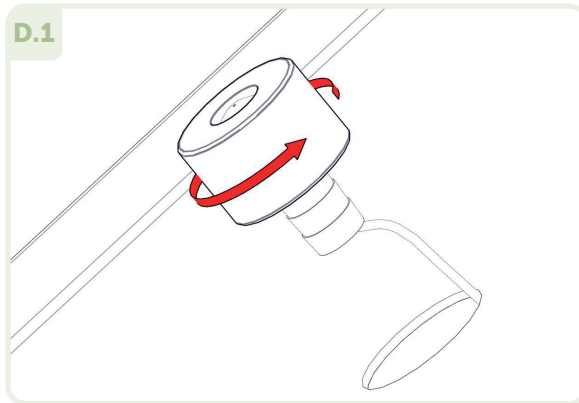

**E.** Replace the LED fountain. Pull the entire plug through the conduit and through the hole in the water table surface. The new LED fountain must also go back through the conduit to the plug point. Use a pull wire if necessary.

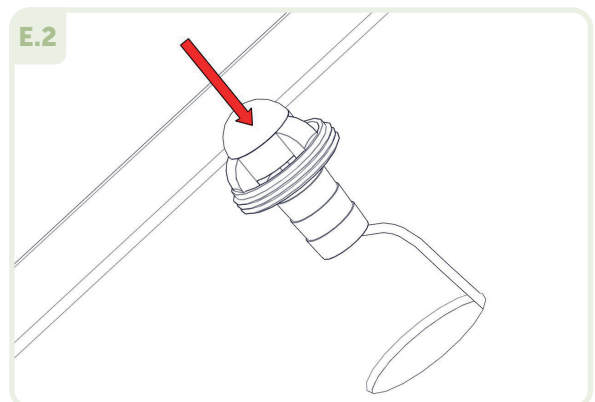
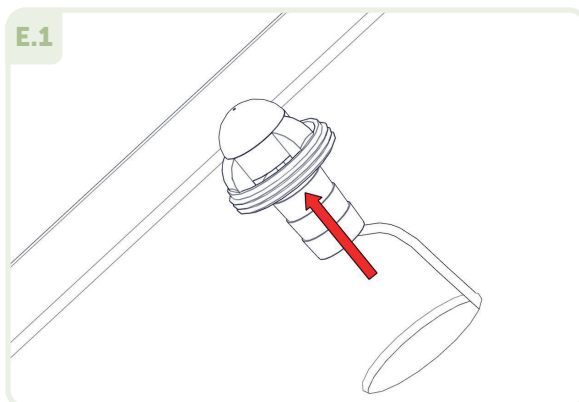

**F.** Clean the ring between the lamp and the holder.

**G.** Place the cap on the LED fountain and screw it back on.

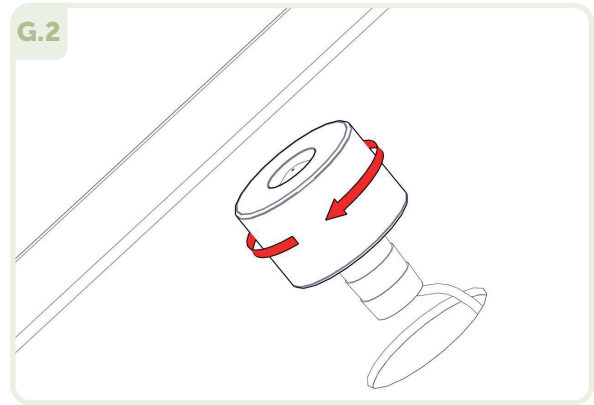
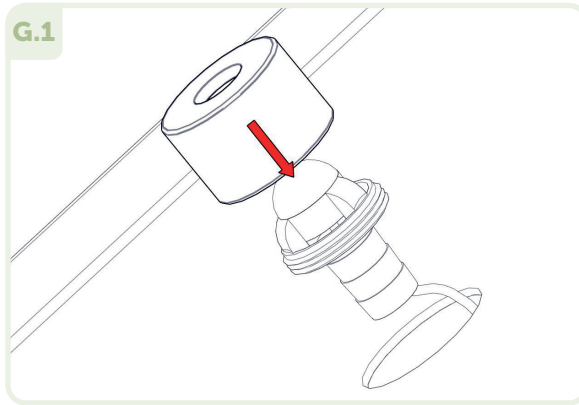

**H.** Put the LED fountain back into the water table surface.

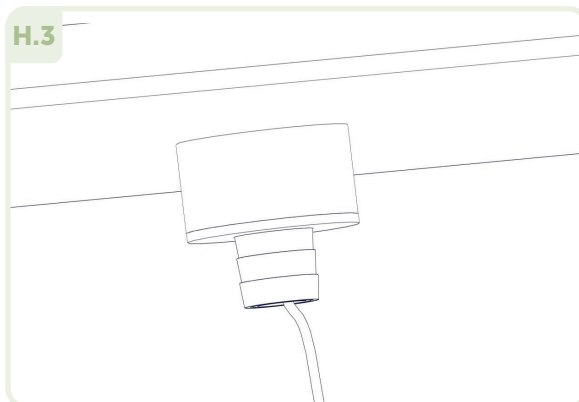
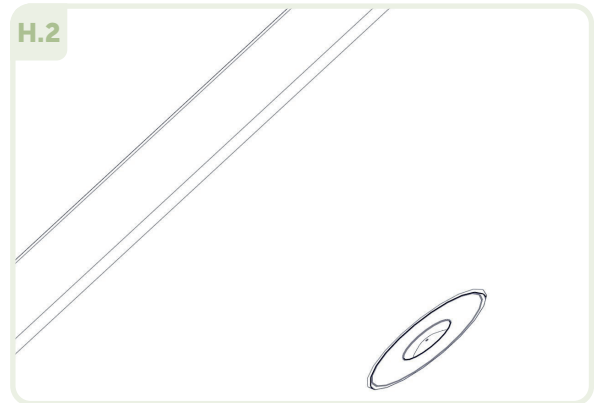
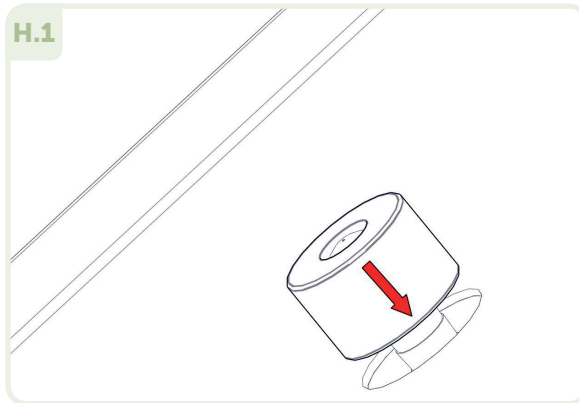

**I.** Place the hose clamp on the LED fountain.

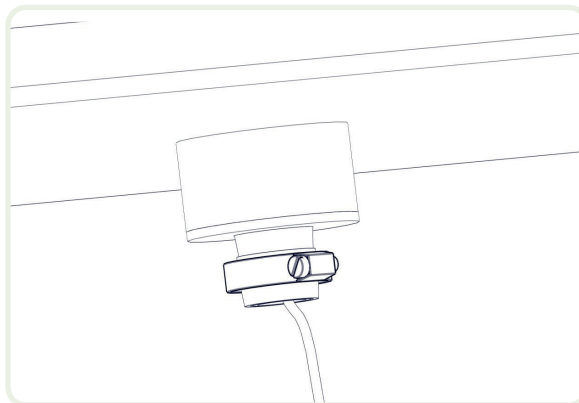

- J.** Push the LED fountain back into the water hose.

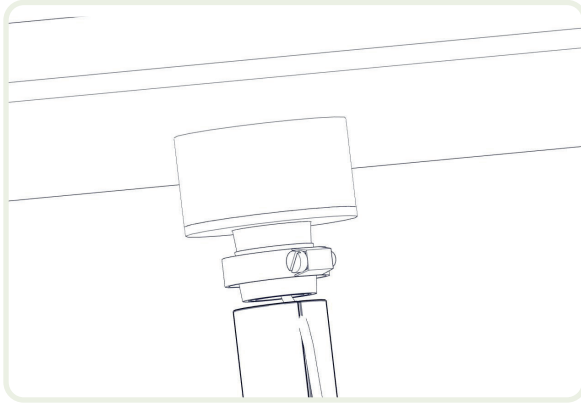

- K.** Tighten the hose clamp again.

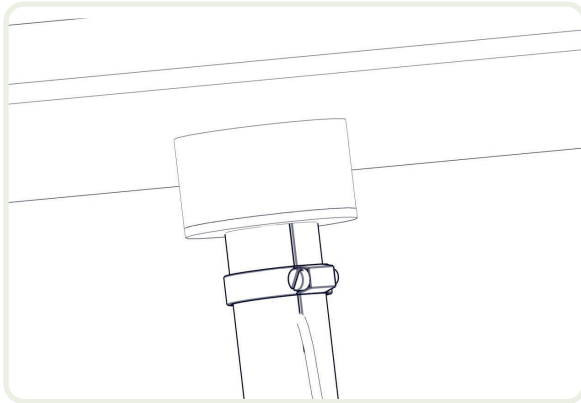

- 4.** Close the water table. See paragraph 5.2 'Opening and closing the water table' for the correct way to close the water table.
- 5.** Check the operation of the lighting.

## 5.7 REPLACING THE PUMP

When replacing, use only electronic parts supplied by ADEZZ.

- 1.** Unplug the power cords.
- 2.** Open the water table. See paragraph 5.2 'Opening and closing the water table' for the correct way to open the water table.
- 3.** Replace the pump as described in the pump manual. This is included with the new pump. Contact our customer service if this is not the case.
- 4.** Close the water table. See paragraph 5.2 'Opening and closing the water table' for the correct way to close the water table.
- 5.** Check the operation of the lighting.

## 5.8 FOUNTAIN MAINTENANCE

The water from the fountains should come out in a straight stream about 10 centimeters high. If this is not the case, there could be several reasons:

- There is visible dirt in the fountain. Unplug the power cord of the water table and remove the dirt from the fountain. Then turn the water table back on. No improvement? Look further.
- Ensure that the fountains are not set too hard or too soft. See paragraph 4.4 'Adjusting Fountains' for the correct adjustment of the fountains.
- There is small debris between the LED fountain and the water table surface.

1. Open the water table. See paragraph 5.2 'Opening and closing the water table' for the correct way to open the water table.
2. Loosen the hose clamp.

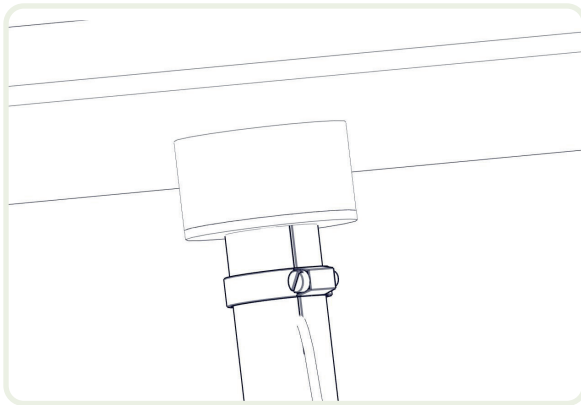

3. Remove the water hose from the LED.

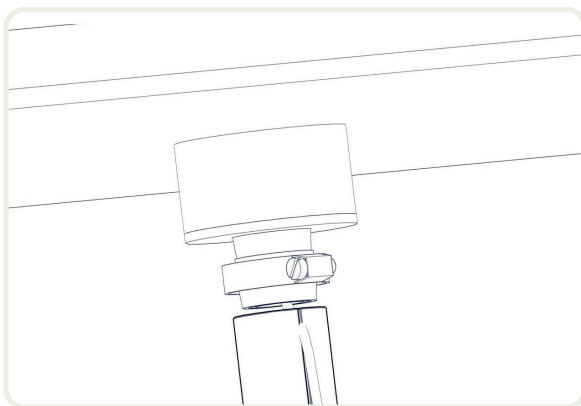

4. Remove the LED fountain from the water table surface.

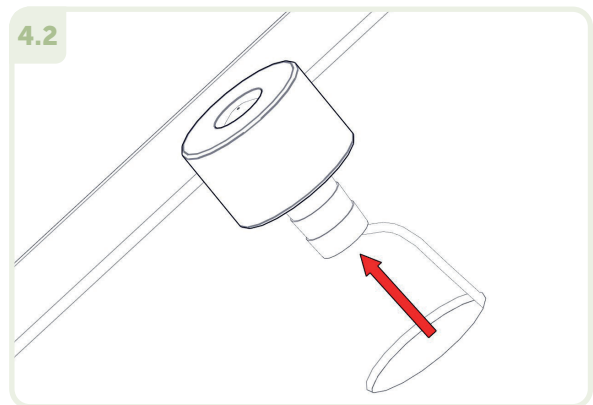
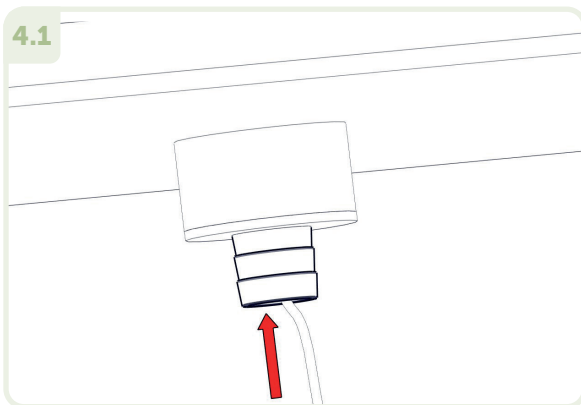

5. Unscrew the cap from the LED.

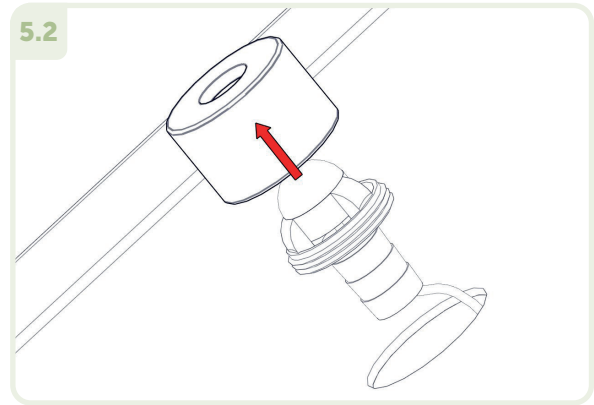
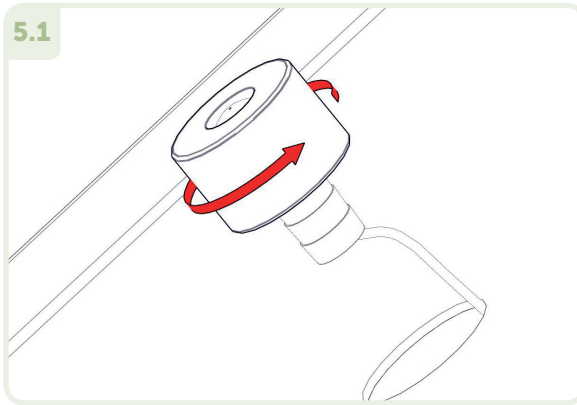

6. Clean the ring between the lamp and the holder.

7. Place the cap on the LED fountain and screw it back on.

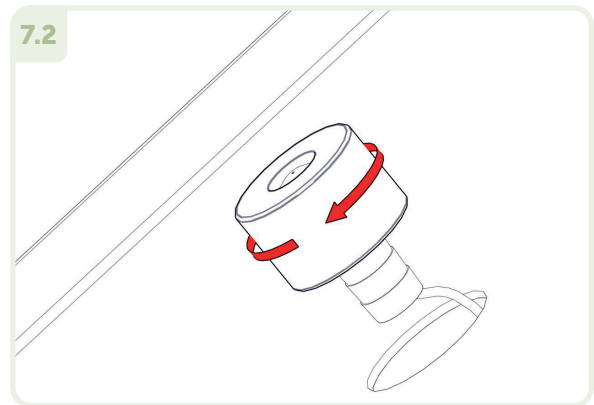
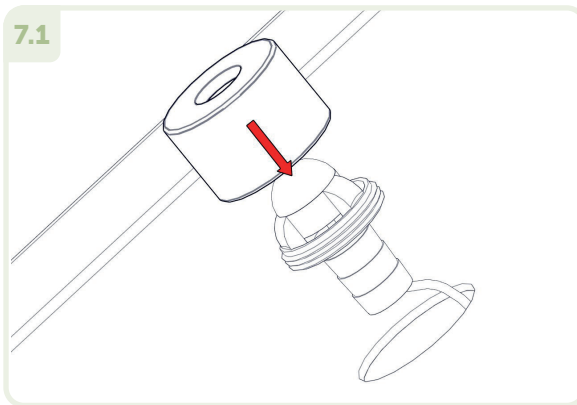

8. Put the LED fountain back into the water table surface.

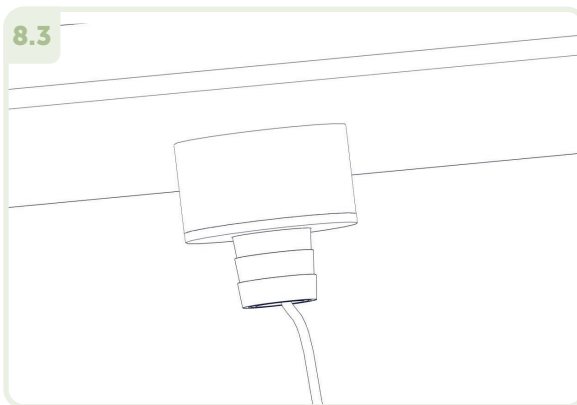
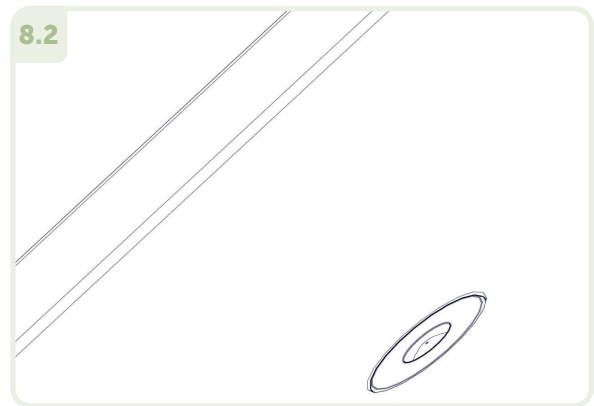
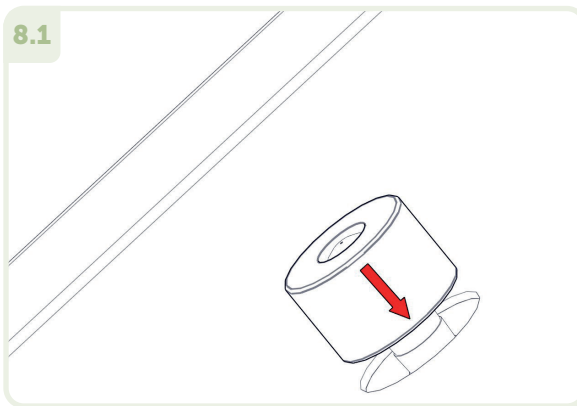

9. Place the hose clamp on the LED fountain.

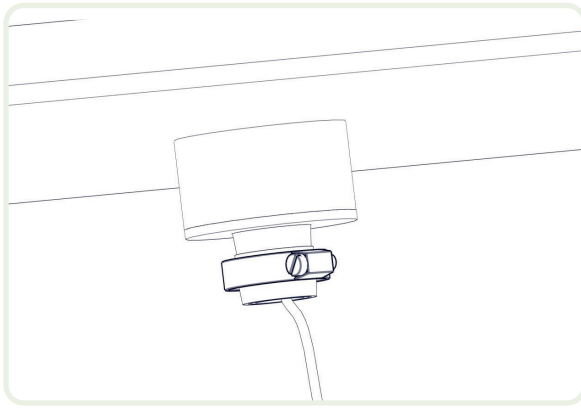

10. Push the LED fountain back into the water hose.

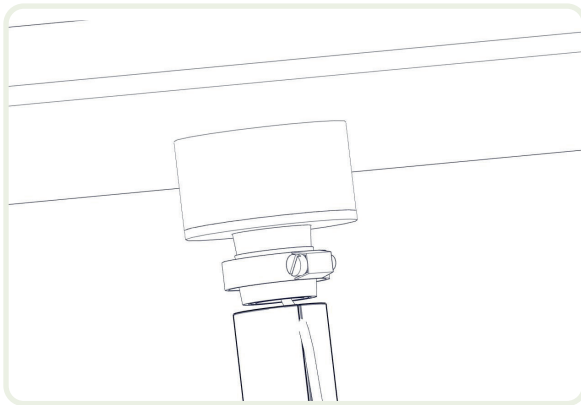

11. Tighten the hose clamp again.

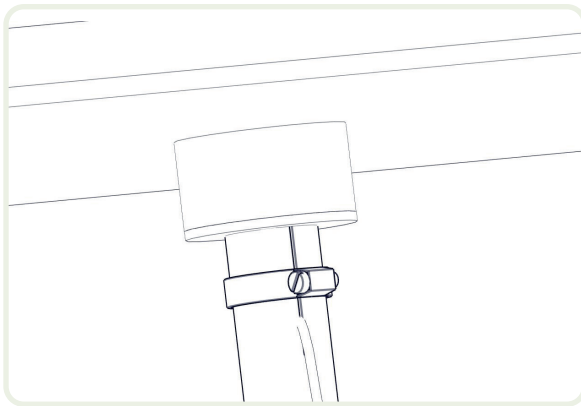

12. Close the water table. See paragraph 5.2 'Opening and closing the water table' for the correct way to close the water table.
13. Ensure that the LED fountain is properly fixed in the water table and that the water hose is not crooked.

## 5.9 USE IN FROST

The water table requires extra attention during frost. Follow the steps below to ensure that the pump of the water table does not freeze during frost.

**Note!** Always unplug the power cord during frost!

1. Open the water table. See paragraph 5.2 'Opening and closing the water table' for the correct way to open the water table.
2. Place a frost protector in the water table. The frost protector. A frost guard is sold at the hardware store.
3. Ensure that the pump always remains under water to prevent lime formation.